

FIRE DAMPERS

Mech-Elec®

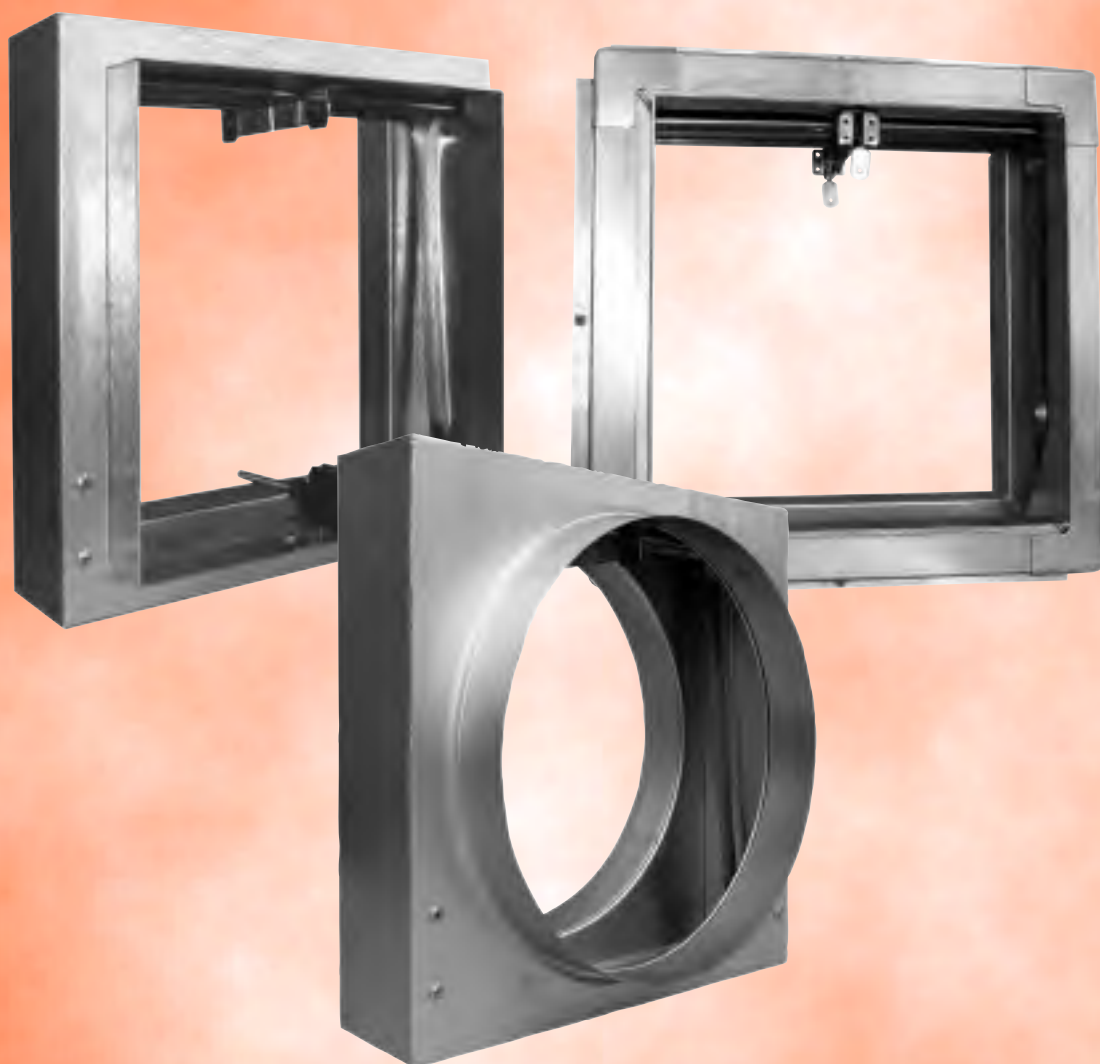

FD
SERIES

Product Specifications and Features

Introduction

The FD Series Steel Curtain Fire Damper is designed to stop the spread of fire through ducts, walls, floors and ceilings.

The product range has many features and options to meet the requirements of specifiers, contractors, local and national authorities. There are five casing variants with infinite sizing capability within minimum/maximum dimensions. Dampers are available to suit low/medium and high velocity applications.

Specifications and Testing

* Fire tested to:

- European standard EN 1366 - 2:1999
- International Standard ISO 10294 - 1:1996(E)
- Horizontal Test Report for 4 hour duration TE 201814
- Vertical Test Report for 4 hour duration TE 201633

and

* Fire tested to BS 476 part 20:1987 for four hour duration

- Warrington Report WFRC C43264 (stainless steel blades)
- Warrington Report WFRC C43265 (galvanised blades)

* 28 day salt corrosion test

- Chatfield Reports C7217 and C7218 refer

* Conformance to DW144 and Eurovent 2/2 as relevant

Features

- * Low/medium and high velocity models
- * Galvanised or stainless steel blades and casings
- * Factory fitted HEVAC approved installation frame, or, other approved methods as shown on pages 5, 6 and 7
- * Fully welded construction
- * Infinite sizing capability
- * Comprehensive control options
- * Comprehensive status options
- * Tested for a duration of four hours

Blades

The roll-formed interlocked steel curtain section is available in either cold reduced hot dipped galvanised mild steel or stainless steel.

Formed within the full length of the blade are dual swages which provide additional strength and rigidity to form a high integrity interlocking blade.

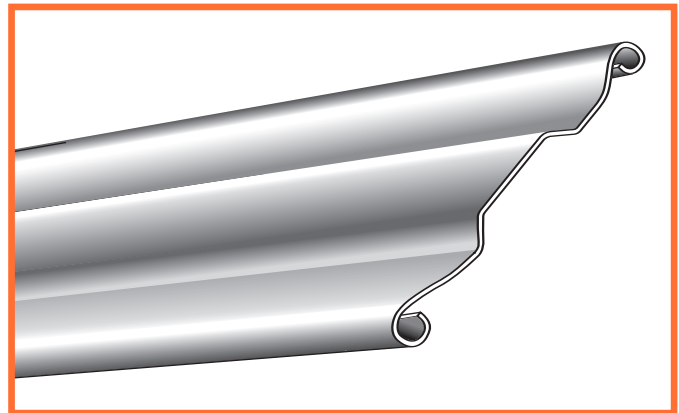

Product Specifications

Fusible Link

Blades are held in the open position by a straight bar link (fitted as standard) rated at 72°C (162°F) with a formed reinforcing swage and two location holes.

- The fusing alloy is to BS 219. The brass is to BS 2870 and is electro-tinned and soldered following this process.
- BSB can supply the FD Series Fire Damper with the alternative rated fusible link for higher temperature applications as follows: 95°C (202°F), 124°C (260°F), 145°C (286°F), 182°C (360°F).

The Fusible Link Bracket is manufactured from Grade 430 stainless steel as standard to: BS 1449 Part 2 1983 S172.

Blades

Formed to provide a continuous interlocking hinge extending the full length with dual swages providing maximum strength and rigidity. Not less than 0.7mm (22swg) thick cold reduced hot dipped galvanised mild steel to BS EN 10142 1991. Coating Class FE P02b Z275 NA as standard.

Optional to order are Blades to Grade 430 or Grade 316 stainless steel to BS 1449 Part 2 1983 S172B.

Control Options

A range of direct acting or remote control release options are available to operate in conjunction with the gate latch release.

Gate Latch Release

Optional mechanism for electrical release when required. Rated 72°C (162°F), alternative ratings available as per standard straight bar link.

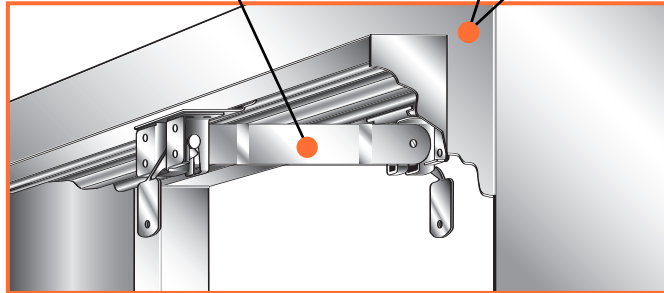

Paint

All welds, seams and joints are sprayed with commercial grade zinc based paint.

Sealant

Where applicable, sealant conforms to DW144.

Casing

Formed to provide two continuous internal flanges not less than 25.4mm (1").

Casing and components not less than 1.5mm (16swg) thick cold reduced hot dipped galvanised mild steel to BS EN 10142 1991. Coating Class FE P02b Z275 NA as standard.

Optional to order are casings to Grade 430 or Grade 316 stainless steel to BS 1449 Part 2 1983 S172.

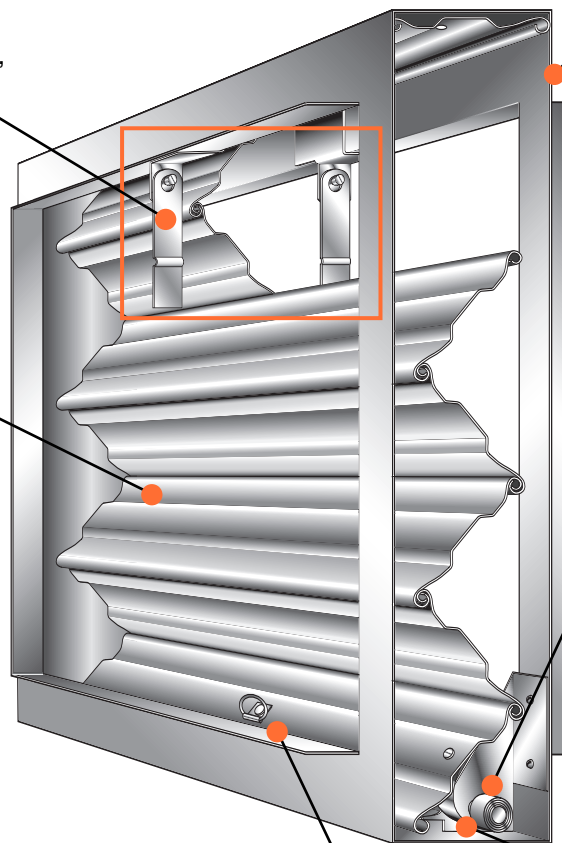

Closure Springs

Dampers are supplied with two constant force coil springs exerting a pull of not less than 35N, with one end fixed to the leading blade by rivets and the coil fitted into the spindle of the locking ramp. The spring is manufactured from Grade 302 stainless steel to BS 5770, 4 hard.

Microswitches

All BSB FD Fire Dampers are available with factory fitted single or double pole microswitches as optional extras. (See page 9)

Pull Ring

Closing blades can be fitted with pull ring to facilitate resetting the damper from the non-access side.

Locking Ramps

Dual locking ramps ensure positive closing action of the blade pack in horizontal or vertical installations.

Dimensions

Type A Square/Rectangular Spigot Blades partially in Airstream

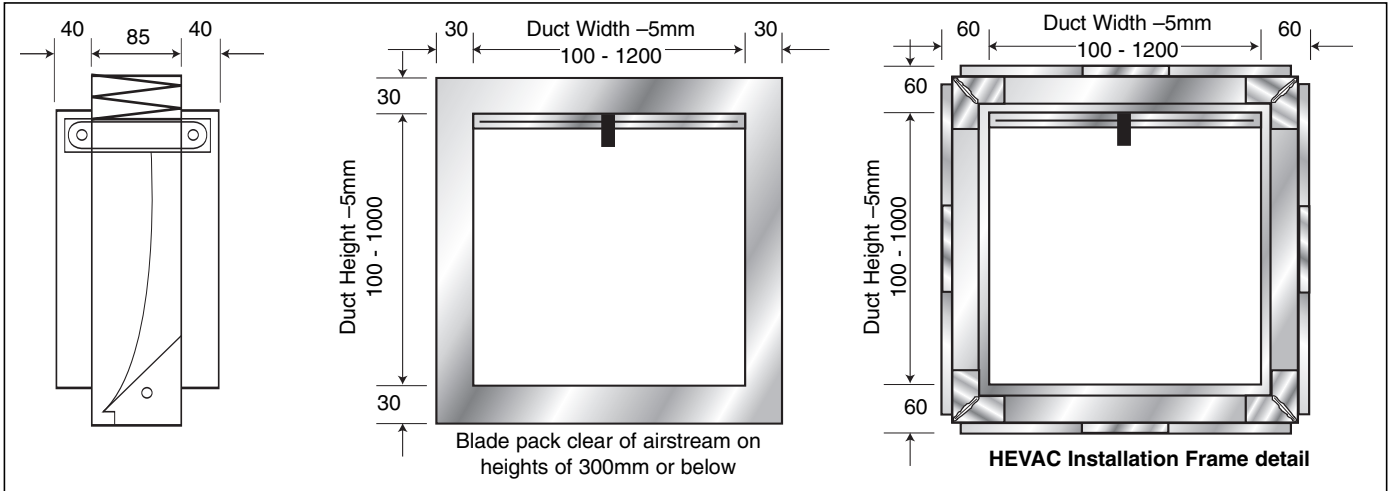

Type B Square/Rectangular Spigot Blades out of Airstream

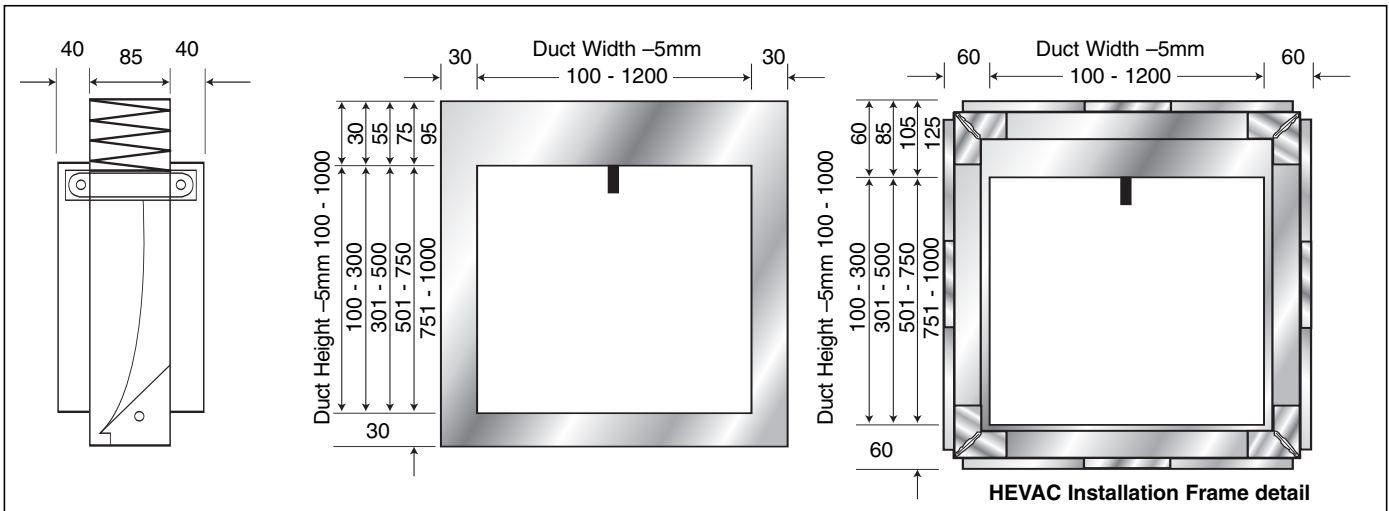

Type I Square/Rectangular Case "Induct" Blades partially in Airstream

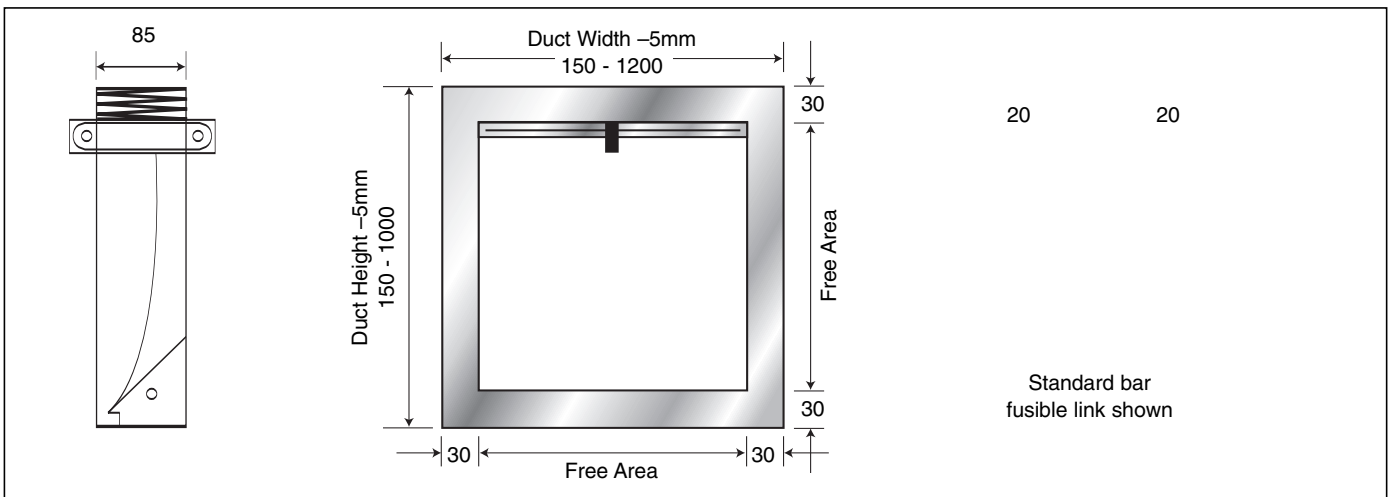

Dimensions

Type C Circular Spigot Blades out of Airstream

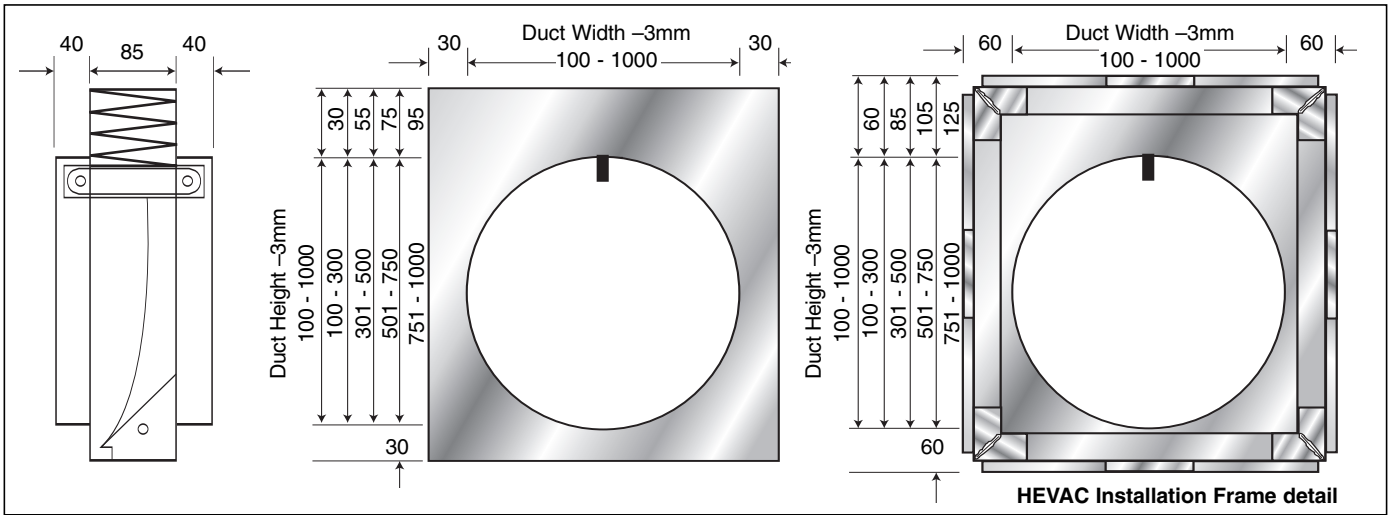

Type O Flat Oval Spigot Blades out of Airstream

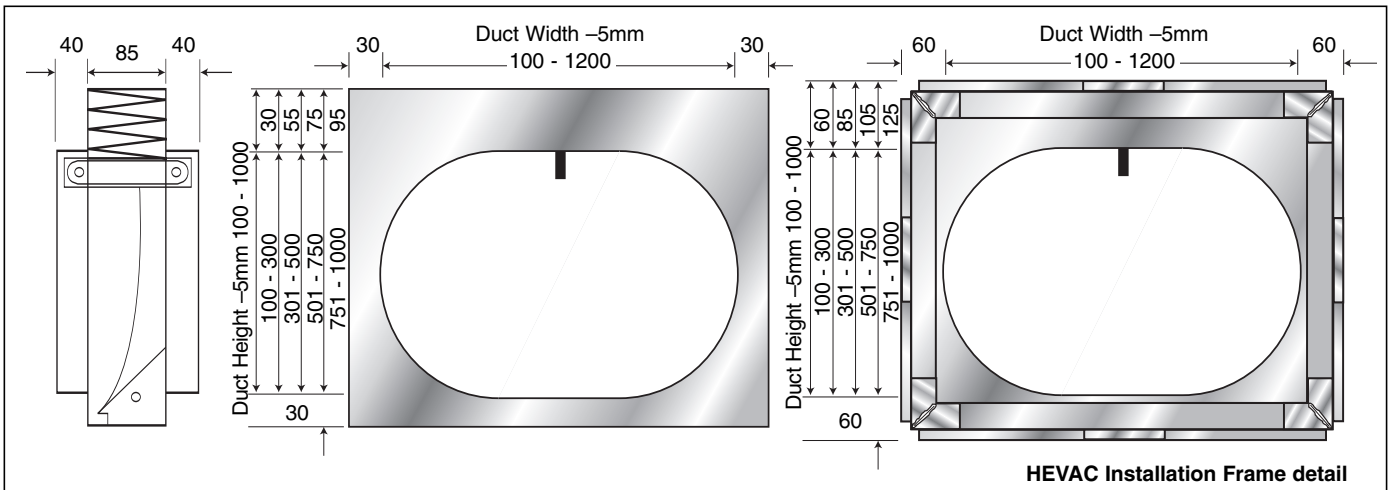

Notes: 1. All dimensions are in mm 2. Spigoted Models are supplied with actual spigot dimensions nominal less 5mm ± 1mm (3mm ± 1mm for type C)
3. For sizes greater than detailed maximum sizes, multiple section units would be supplied

HEVAC/HVCA Installation Frame

The installation frame is factory fitted around the Fire Damper to allow expansion without either distorting or exerting severe stresses within the surrounding structure within which the assembly is installed.

The frame is formed with a "Z" section using galvanised mild steel 1.6mm (16swg) to BS EN 10142 1991. Coating Class FE P02b Z275 NA.

Corner brackets manufactured from 1.5mm galvanised mild steel are fixed to the "Z" section by four 5mm (3/16") diameter aluminium rivets.

A number of fixing tie tabs are positioned equally along each side of the frame, (as indicated below) for positive fixing into the surrounding builder's work to maintain structural integrity.

Duct Dimension (mm)	No. of equally spaced fixing points per side
Up to 508	1 Minimum
509 to 1016	2 Minimum
1017 to 1524	3 Minimum

Installation Frame Corner Brackets

* Dimensions marked thus indicate overall dimensions including HEVAC installation frame "crimple" on corner brackets.

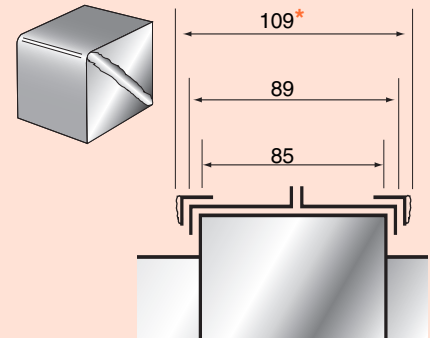

Installation

HEVAC/HVCA Frames

The HEVAC/HVCA approved factory fitted Installation Frame is designed to allow expansion of the damper under fire conditions, without affecting its integrity or the construction it is installed within.

One Piece Corner Bracket

The one piece pressed corner bracket is rivetted (using aluminium rivets) to the "Z" Section which makes the frame. This bracket allows the frame to expand under fire conditions without affecting the integrity of the construction it is installed within.

Fixing Tie Tabs

For securing the assembly into the builders work structure as specified by the specifying/authorising authority.

Expansion Corners

These pressed corners are fitted into each corner to permit expansion of the fire damper within the construction of the frame.

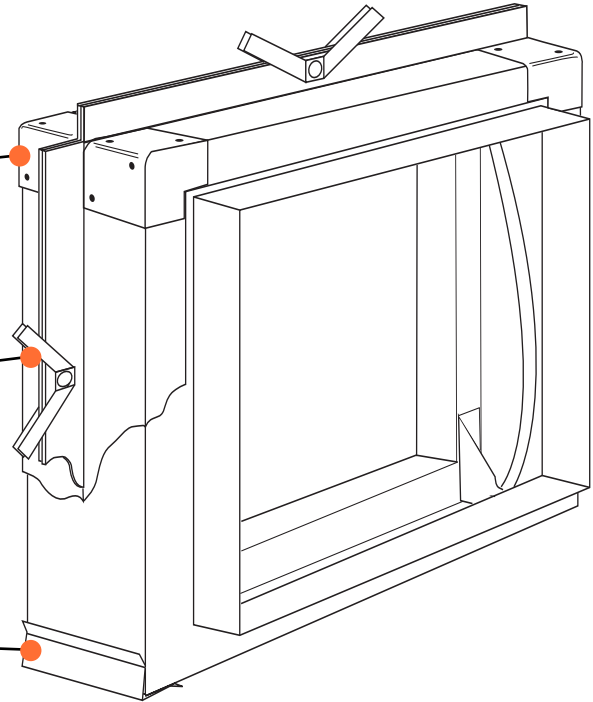

Installation Codes of Practice

The frame should be installed centrally within the thickness of the surrounding wall or floor. Or, in the case of thick walls or floors, the centre line of the frame should be at least 50mm away from the nearest face.

Where more than one duct penetrates a wall or floor, adjacent fire damper assemblies should be separated by builder's work of a minimum thickness of 225mm. During installation, all fixing tabs should be bent out and built into the surrounding structure so as to ensure "positive fixing into the surrounding builder's work".

The illustrated detail on this page is BSB's interpretation of the HEVAC/HVCA Installation Frame specification. For additional details, contact our sales office.

Special Note:

All fire damper installations should be carried out to the satisfaction of the appropriate district surveyor, fire officer and/or specifying authority as other approved methods of installation may well be used.

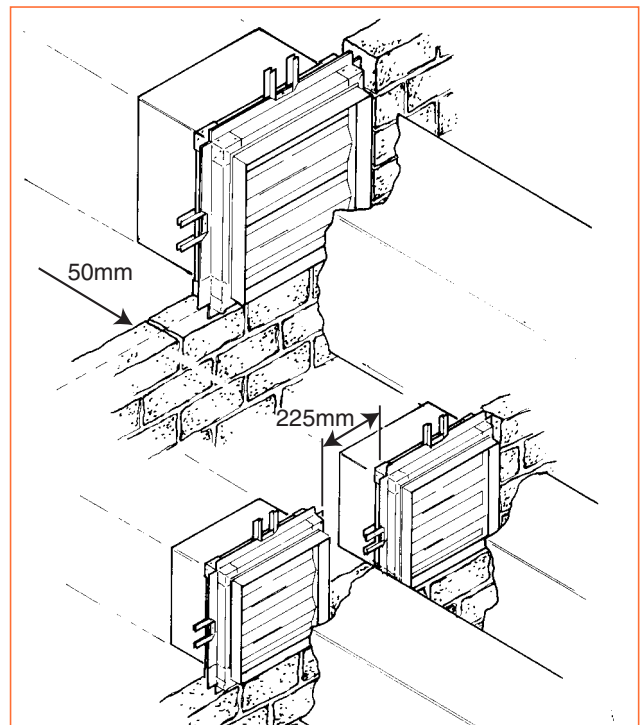

Installation Parameters

FD Series Fire Dampers are designed for application in normal dry filtered air systems. If exposed to fresh air intakes and/or inclement conditions the damper should be subject to a planned inspection programme.

Installations involving corrosive and/or aggressive hostile environmental conditions (e.g. swimming pools) may invalidate our warranty and should be referred to our Sales Office.

Installation

In Brick/Block Wall

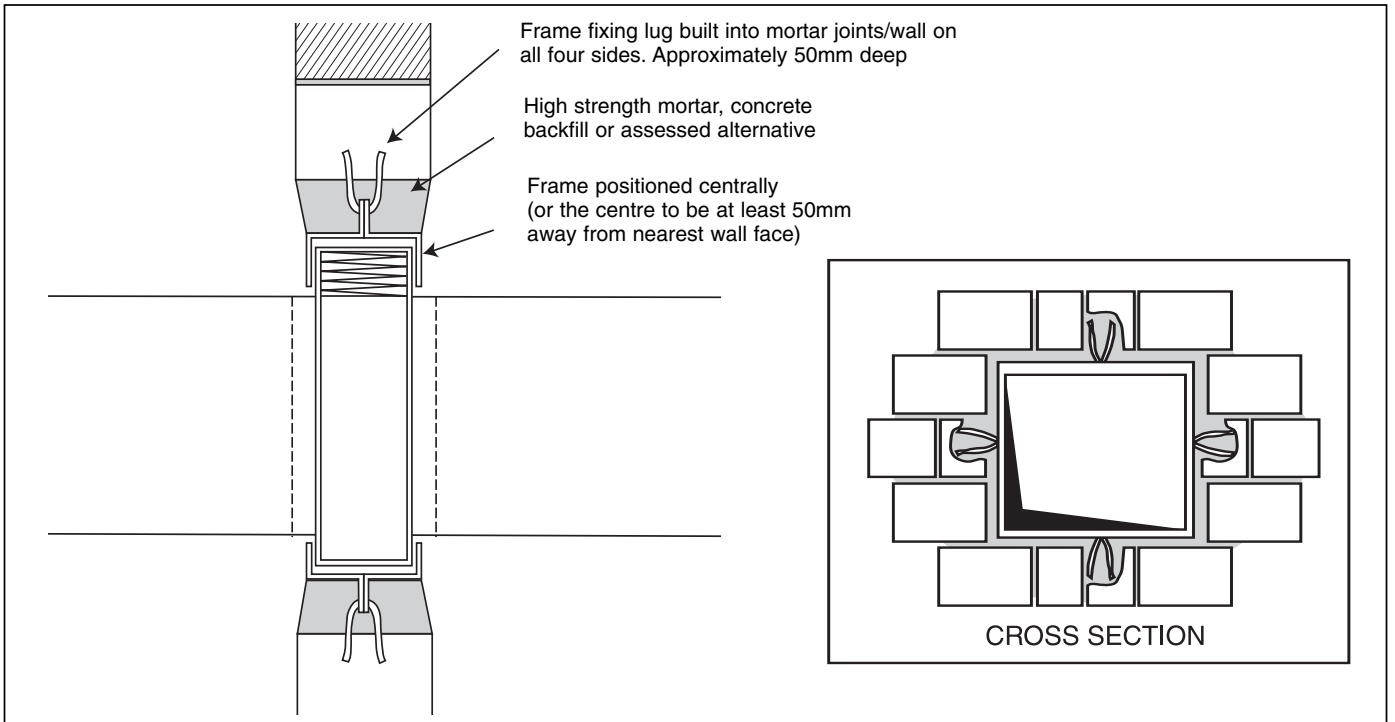

Special Note: All fire damper installations should be carried out to the satisfaction of the appropriate district surveyor, fire officer and/or specifying authority as other approved methods of installation may well be used.

In Fire/Smoke Curtain

Special Note: The methods detailed in these illustrations are proposed methods only. Acceptance must be sought from the specifying authority prior to ordering or installation. These options must be factory fitted prior to despatch.

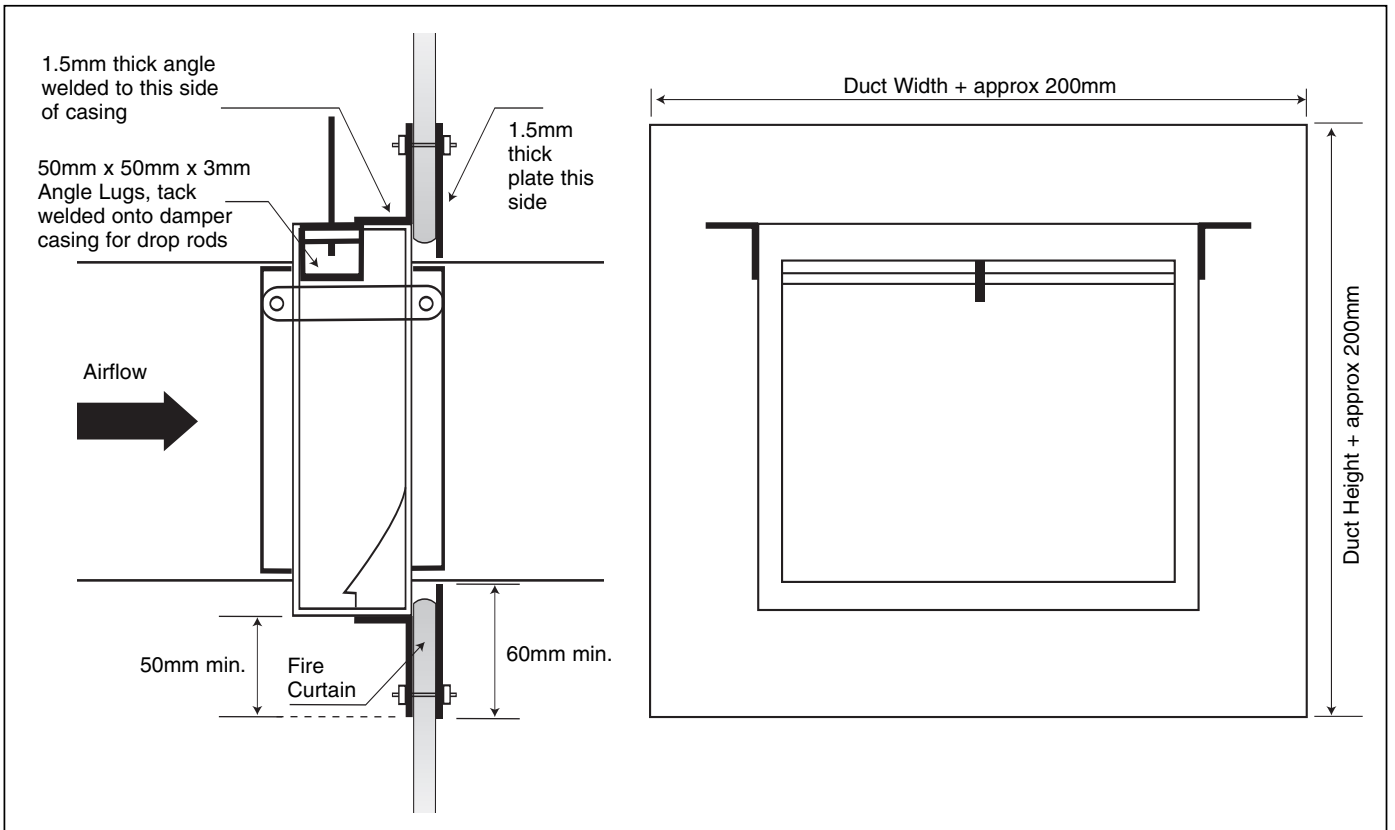

Installation

Dry Line Partition Walls

Special Note: The methods detailed in these illustrations are proposed methods only. Acceptance must be sought from the specifying authority prior to ordering or installation. These options must be factory fitted prior to despatch.

Sleeve and Angle Method

Angle Frames are to be bolted onto the sleeve by the installer.

External sleeve around Fire Damper for Low Velocity Duct connection

External sleeve fitted onto the Fire Damper for High Velocity Duct connection

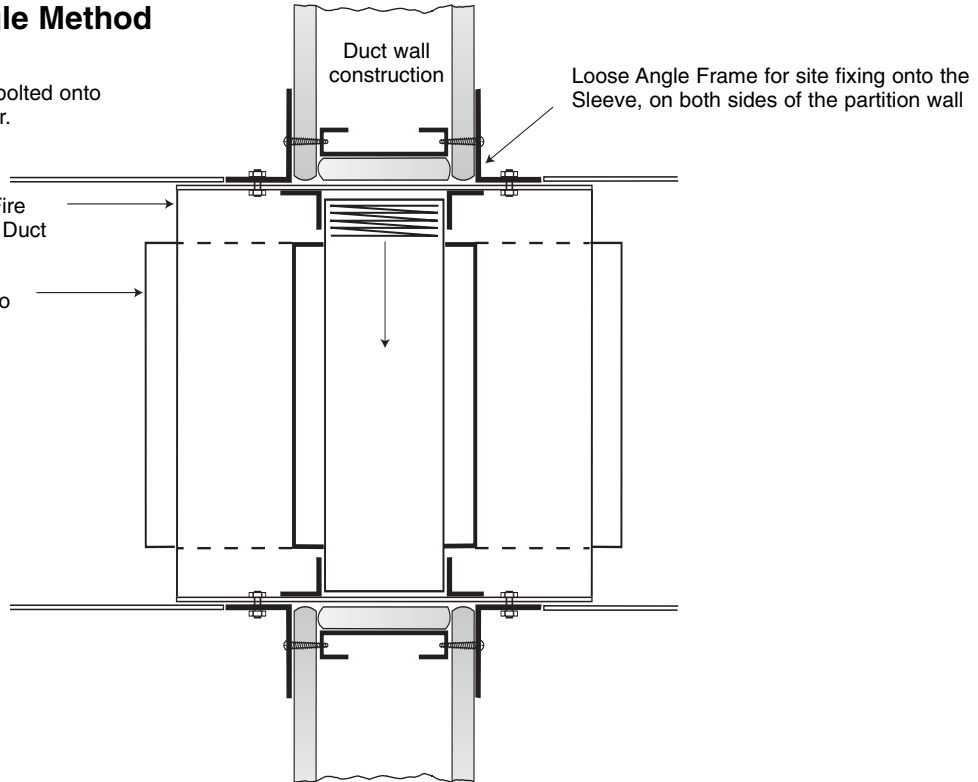

**HEVAC
Frame with
Dry Liner
Plate**

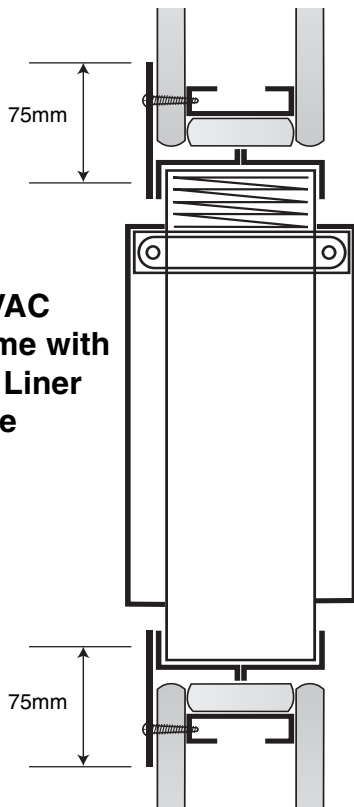

**Angle
Frame
Method**

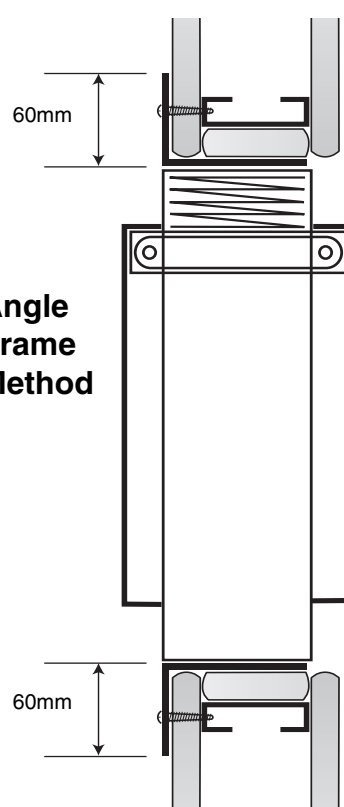

It is recommended that slotted holes are inserted for linear expansion within this "L" formed frame

Special Note: All fire damper installations should be carried out to the satisfaction of the appropriate district surveyor, fire officer and/or specifying authority as other approved methods of installation may well be used.

Installation

In Wall - "Z" Frame

Special Note: The methods detailed in these illustrations are proposed methods only. Acceptance must be sought from the specifying authority prior to ordering or installation. These options must be factory fitted prior to despatch.

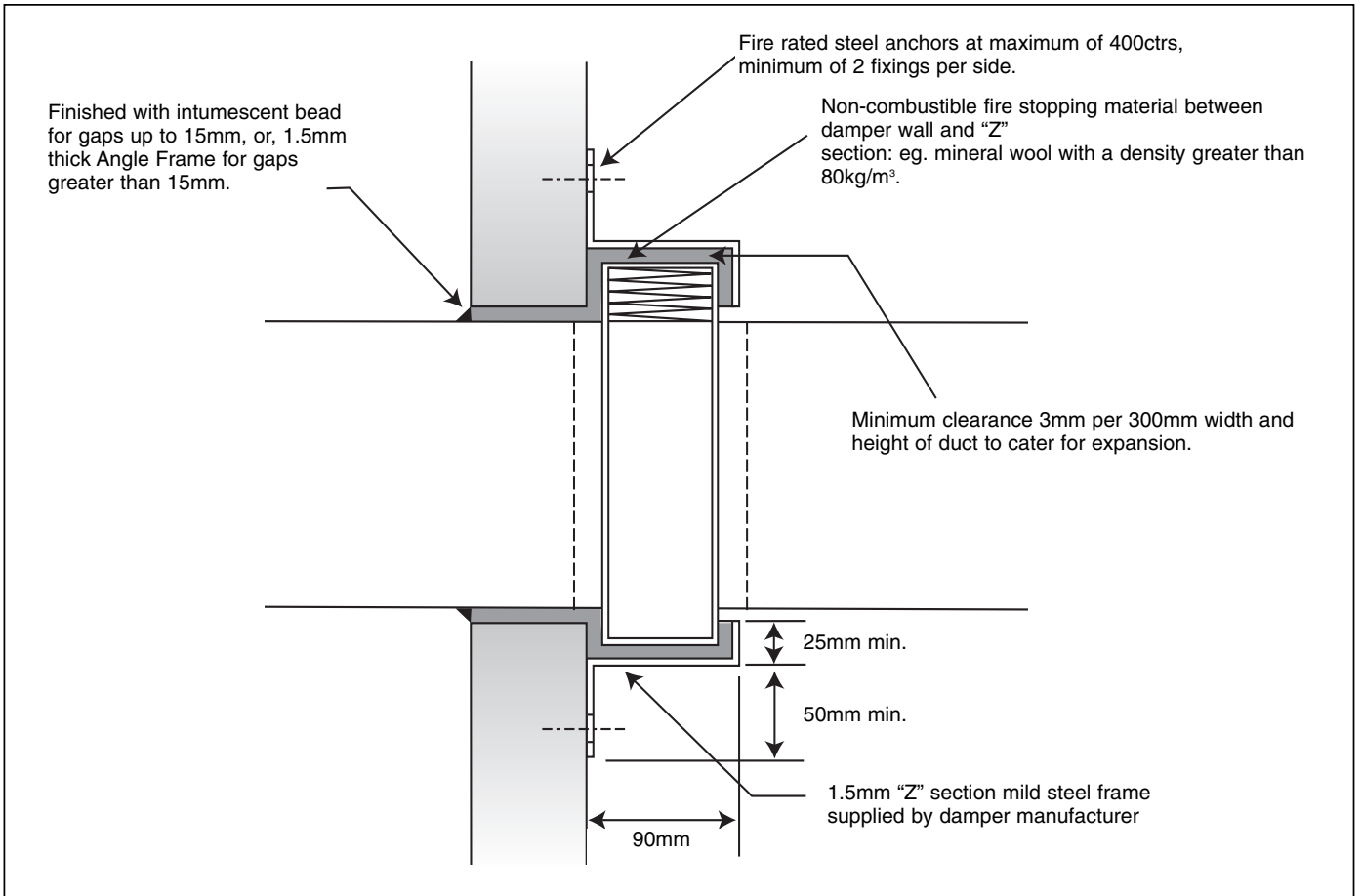

Induct/Sleeve Applications

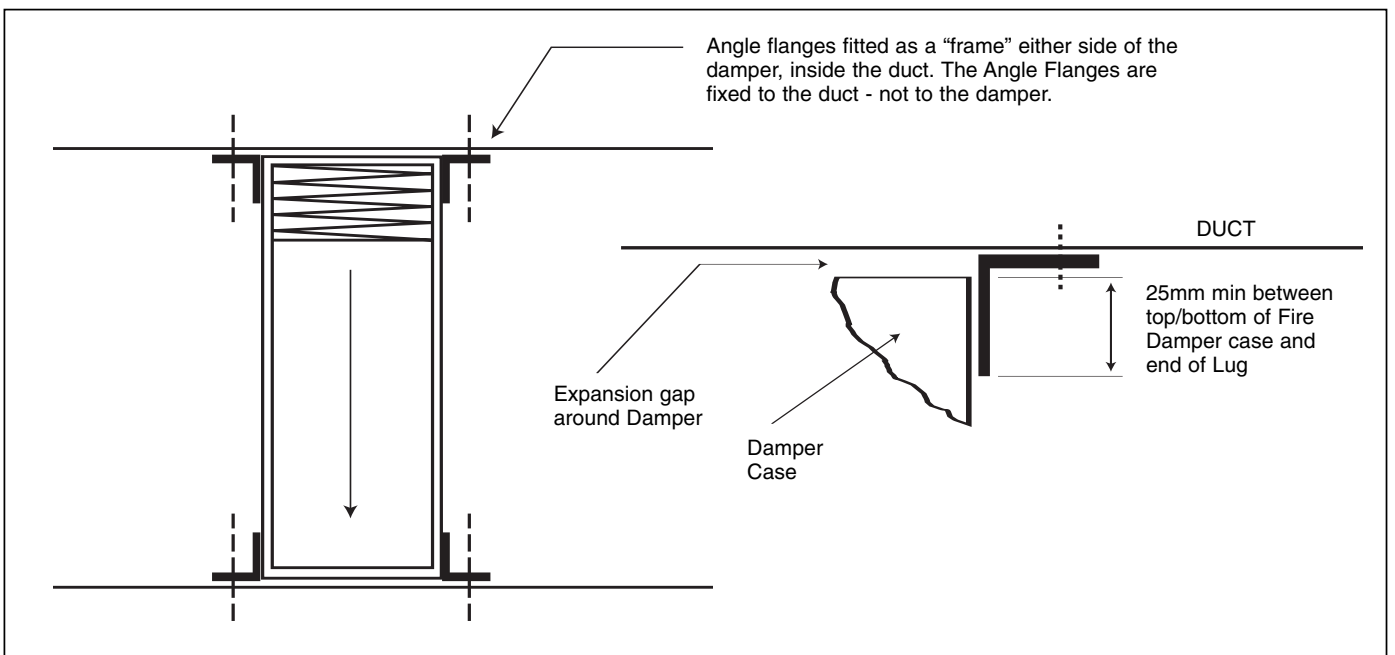

Special Note: All fire damper installations should be carried out to the satisfaction of the appropriate district surveyor, fire officer and/or specifying authority as other approved methods of installation may well be used.

Installation

Fitted with Lugs for Drop Rod Support

Special Note: The methods detailed in these illustrations are proposed methods only. Acceptance must be sought from the specifying authority prior to ordering or installation. These options must be factory fitted prior to despatch.

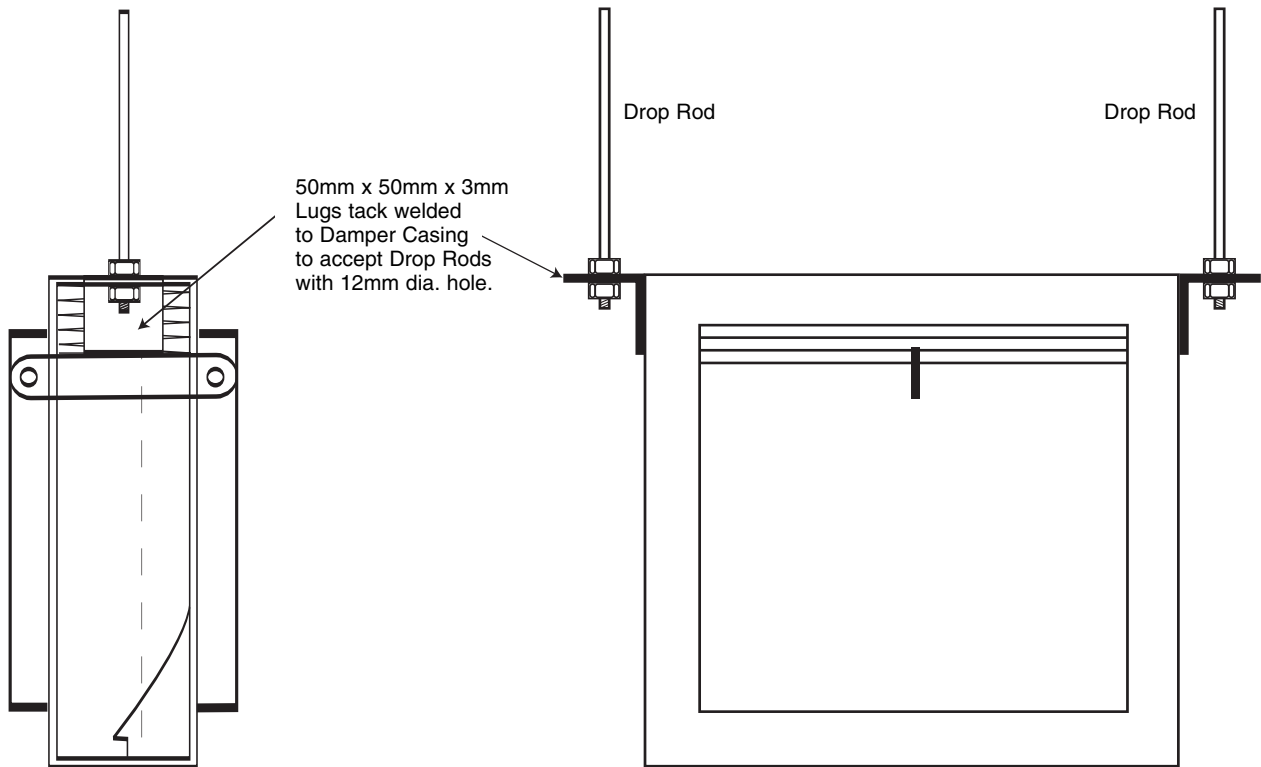

Testing and Resetting

Curtain Fire Dampers will need to be tested and reset through an access panel sited in the adjacent ductwork. It is important to note that the damper should be fitted with the marked "Access Side" downstream, i.e. on the opposite side to that of the incoming air-flow.

The damper blades are spring assisted and will close instantly once the fusible link has been removed. We do not recommend that our fire dampers be closed while the fan is still operating as this will stress the ductwork, fan and damper.

Where there is a rise in temperature and during a fire situation, the fusible link will part in the centre, releasing the blade pack via the release bracket

situated centrally in the width of the case. When drop testing during routine maintenance, this action should be replicated to avoid misfiring. The blade pack must never be supported to one side only when releasing or resetting the blade pack.

Comprehensive testing and resetting information is available via our Sales Office.

Special Note: All fire damper installations should be carried out to the satisfaction of the appropriate district surveyor, fire officer and/or specifying authority as other approved methods of installation may well be used.

Blade Control Options

Mechanical Visual Indicator

To provide local indication of the blade status.

When the indicator appears in the bulb, this shows that the blades have closed.

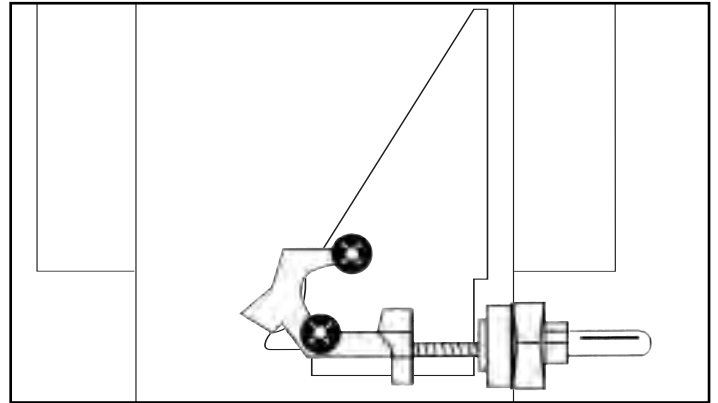

Single Pole Microswitch

To provide remote indication of the blade status. As the leading blade travels to the locking ramp, it contacts the arm and operates the switch. Factory Fitted.

The Single Pole Microswitch is supplied as a dependent snap action contact 1NO + 1NC.

For indication of damper closed, terminals 13 and 14 should be used. Degree of protection: IP66.

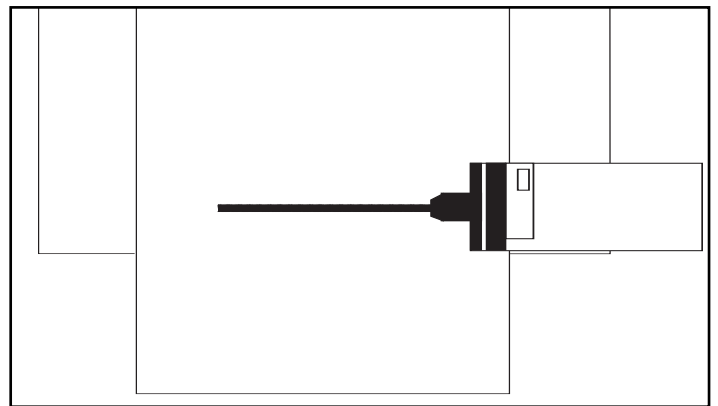
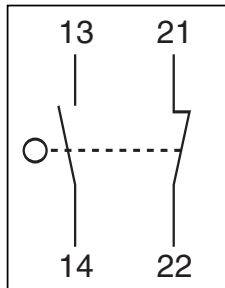

Double Pole Microswitch

Operates as above but with two switches for double pole operation. Can also provide a signal to a control panel enabling isolation of plant in case of fire. Factory fitted

Pole 1 and Pole 2

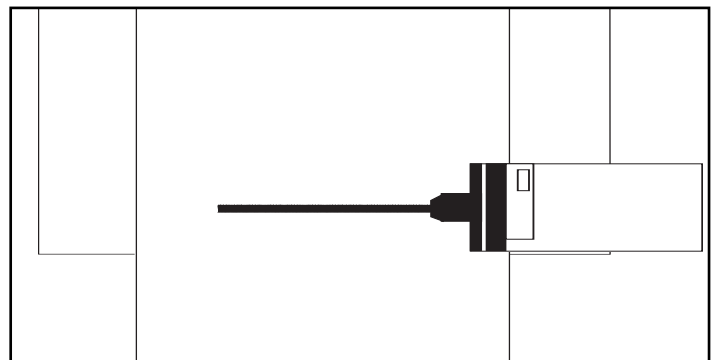
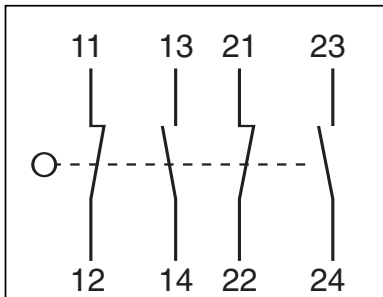

Economy Sealed Microswitch

To provide remote indication of the blade status.

As the leading blade travels over the locking ramp, the lever is depressed and operates the switch.

Factory Fitted.

Degree of protection: Casing and Outlet IP67

Connection details:

- | | |
|---------------------|------------|
| Common (1) | Black lead |
| Normally open (4) | Blue lead |
| Normally closed (2) | Brown lead |

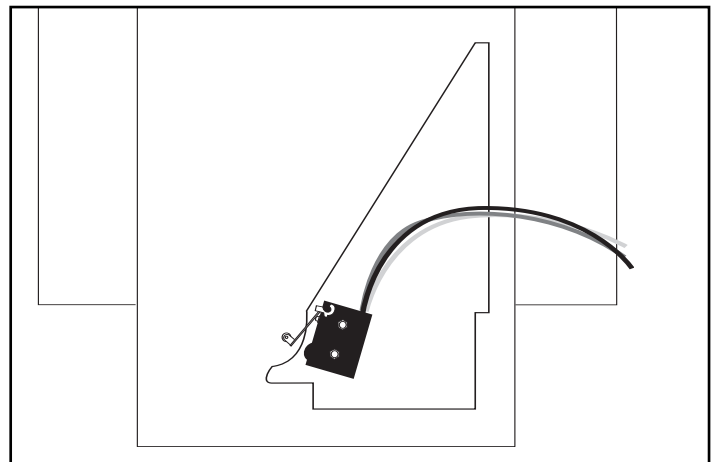
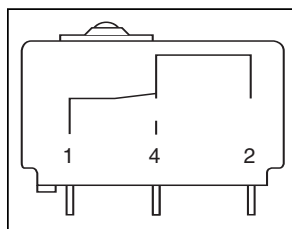

Control Options

Solenoid (De-energised) 240 volt



The Solenoid option is designed for use with 'normally de-energised' systems and releases when a 240VAC detector signal is applied. The solenoid is supplied with the release mechanism housed in a remote casing and comes complete with a 1m length of Bowden cable as standard. For the purposes of remote test firing the damper, a manual release version of the cable operator is available. Note: this option is only suitable for dampers greater than 150mm in height and fitted with the gate latch release mechanism.

A 24 volt option is available.

Available for sizes from 150 x 150mm to 1200 x 1000mm and 150 x 1000mm diameter.

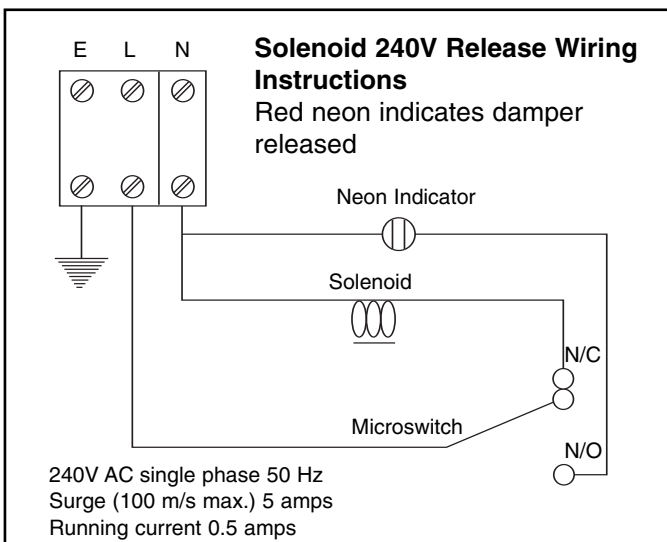

Electro-Magnet (Energised) 24 volt



The Electro Magnet option is designed for use with 'normally energised' systems and releases upon interruption of the power supply.

The electro magnet is supplied with the release mechanism housed in a remote casing and comes complete with a 1m length of Bowden cable as standard. For the purposes of remote test firing the damper, a manual release version of the cable operator is available.

Note: this option is only suitable for dampers greater than 150mm in height and fitted with the gate latch release mechanism.

A 240 volt option is available.

Available for sizes from 150 x 150mm to 1200 x 1000mm and 150 x 1000mm diameter.

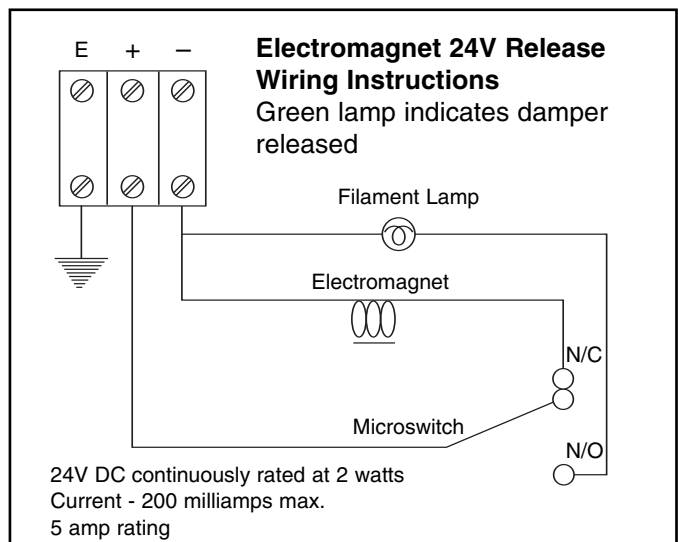

Control Options

Installation Diagram

These illustrations show the electro-magnet control box mounted on the outside of the duct, with a Bowden Cable being fed through the duct to the trigger release mechanism ensuring that the curves of the cable are minimal.

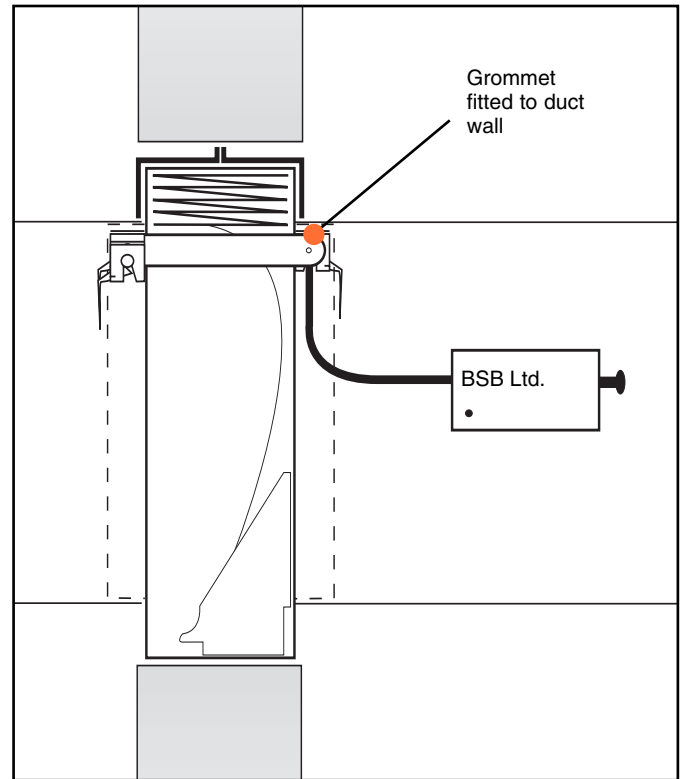
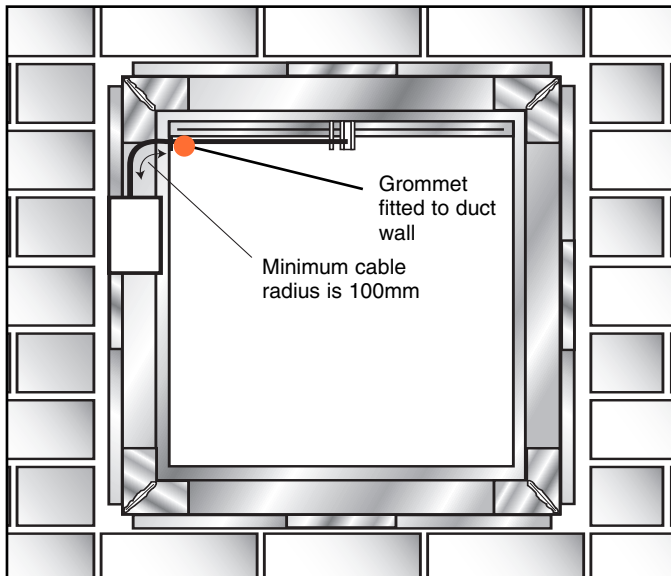

Fusible Link Release

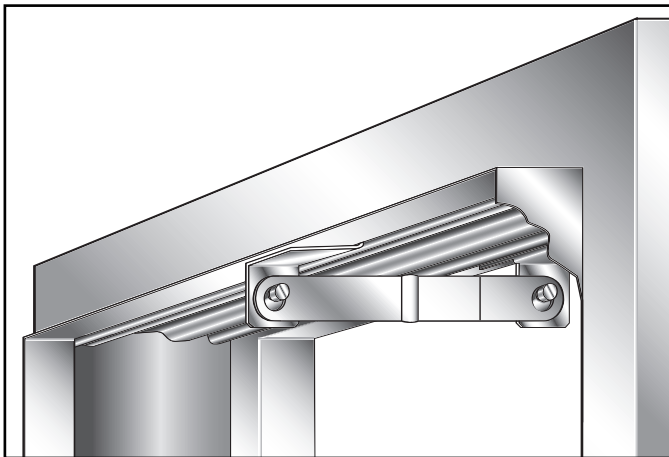

Straight Bar Fusible Link (Standard)

The standard fusible link will be supplied and rated at 72°C unless otherwise specified.

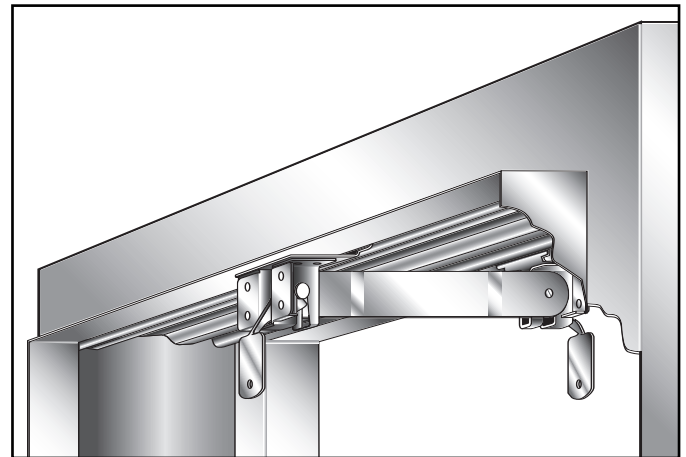

Gate Latch Link Option

Providing a trigger operation feature, this self-locating and easily resettable cassette can be used with either the solenoid or electro-magnet controls - or, as a standard component to assist the engineer in the resetting of the fire damper during regular inspection and maintenance procedures.

Only available from 150 to 1000mm (high).

Performance Characteristics and Weight Chart

Pressure Drop Graphs

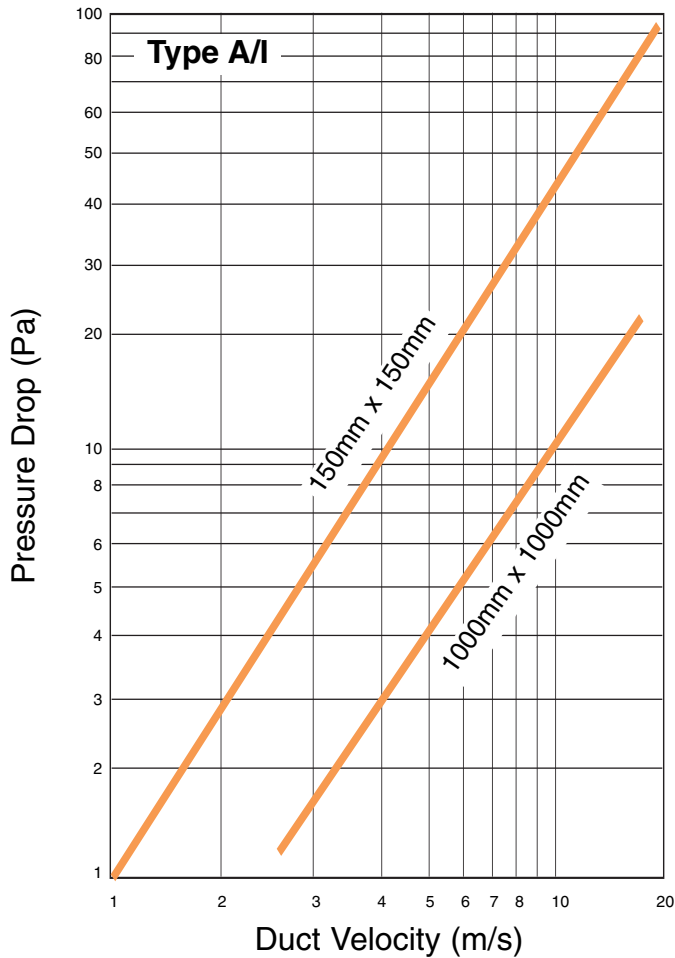

Minimum free area = 91% Velocity range 0 to 12.5 m/s

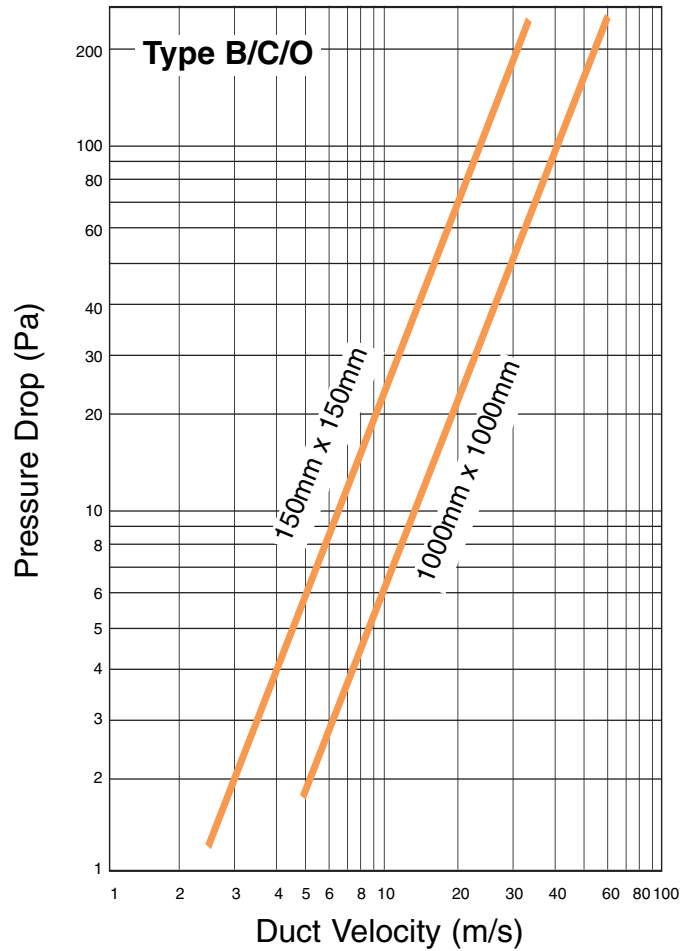

Maximum unrestricted airflow Velocity range 0 to 30m/s

Weight Chart (kg) Models A and B

Damper Height (mm)	Damper Width (mm)										FOR CIRCULAR AND FLAT OVAL MODELS ADD 25% TO THESE VALUES For models with HEVAC/HVCA installation frames, add a further 25%. These values have been rounded to whole numbers and are illustrated for estimation purposes only.
	100	200	300	400	500	600	700	800	900	1000	
100	2.0	3.0	4.0	5.0	6.5	7.0	8.0	9.0	9.5	10.0	
200	3.0	3.5	4.0	5.0	7.0	8.0	9.0	10.0	11.0	12.0	
300	3.5	4.0	4.5	5.5	7.0	9.0	9.5	10.5	12.0	13.0	
400	4.0	5.0	5.5	6.0	7.5	10.0	11.0	12.0	13.0	14.0	
500	5.0	6.0	7.0	7.5	8.5	11.0	12.0	13.0	15.0	16.0	
600	6.0	7.0	8.0	8.0	9.5	12.0	13.0	14.0	16.0	17.0	
700	7.0	8.0	9.0	9.5	10.5	13.0	14.0	15.0	17.0	18.0	
800	8.0	9.0	10.0	10.0	12.0	14.0	15.0	16.0	18.0	19.0	
900	9.0	10.0	11.5	12.0	14.0	15.0	15.5	17.0	18.0	20.0	
1000	10.0	12.0	13.0	14.0	15.0	16.0	17.0	18.0	20.0	22.0	

Performance Characteristics

Fire Test

British Standard 476,
Time Temperature Curve

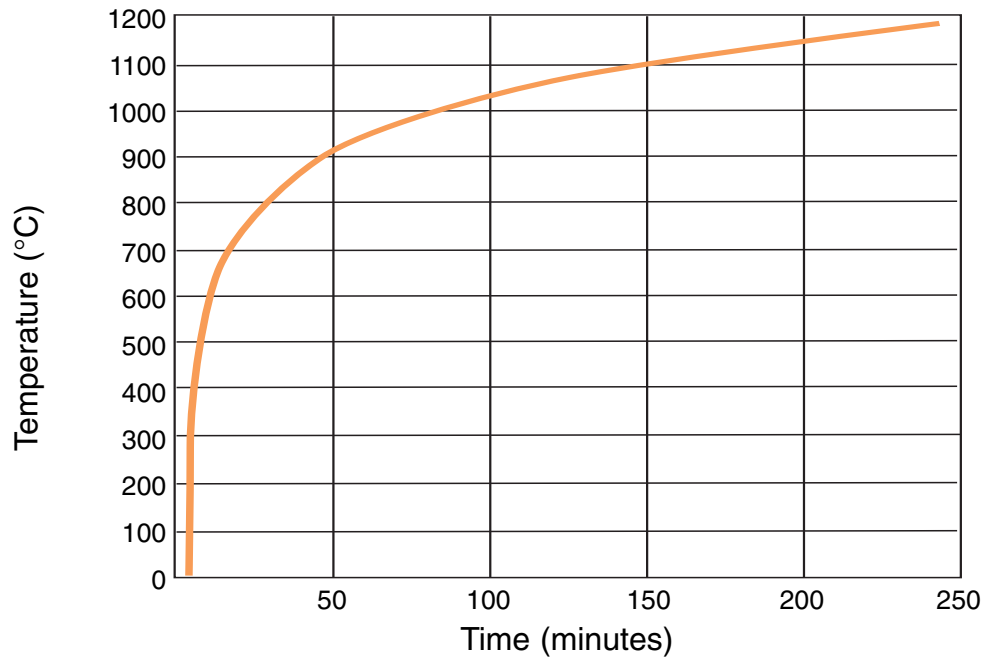

Multiple Assemblies

When Fire Dampers are required to be installed in apertures with dimensions greater than the maximum single unit size, multiple assemblies can be supplied.

Vertical Assemblies

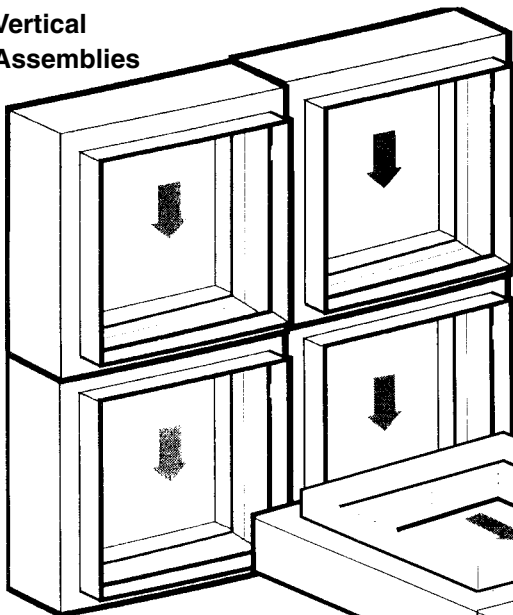

Dampers are either welded together as a multiple construction or alternatively supplied loose with 1.5mm galvanised steel “U” shaped joining channels formed 60mm x 40mm.

These would normally be supplied undrilled for on-site installation by others.

Special Note:

Before installation, proposed multiple arrangements should be agreed with the appropriate district surveyor, fire officer and/or specifying authority.

When multiple units are ordered with HEVAC/HVCA approved installation frames, these would be supplied fully assembled with the installation frame fitted

Horizontal Assemblies

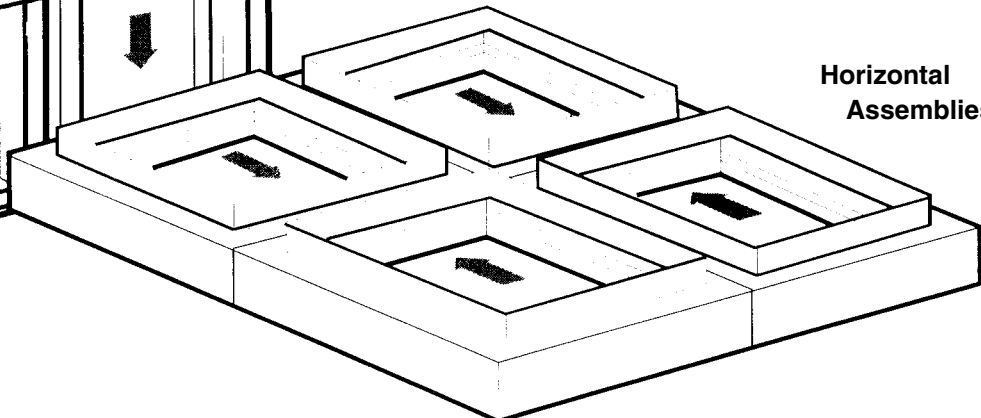

Ordering Codes

Example:

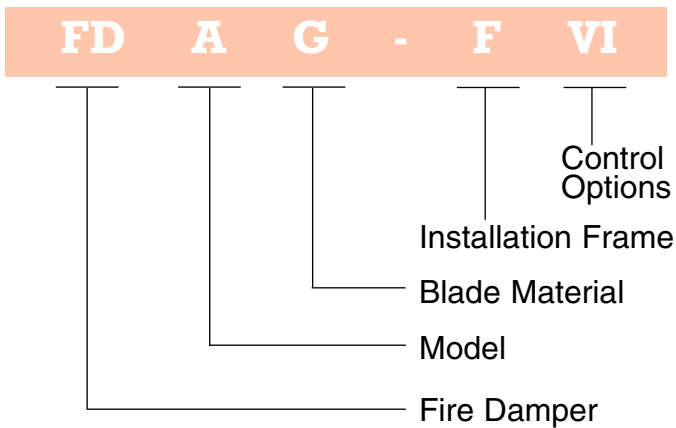

FD Fire Damper

Model:

- A** Low/Medium Velocity
- B** High Velocity
- I** in-Duct - Low/Medium Velocity
- C** Circular - High Velocity
- O** Flat Oval - High Velocity

Blade Material:

- G** Galvanised Mild Steel Roll-formed Blades
- S** Stainless Steel Roll-formed Blades (state grade)

Installation Frames:

- F** Fitted with HEVAC/HVCA Installation Frame

Control Options:

- SL** Solenoid (state voltage)
- EM** Electro-Magnet (state voltage)
- VI** Visual Indicator
- MS** Micro-Switch Fitted (state single or double pole)



BD Series
Backdraught Damper



Control Panel
Electro-Mechanical

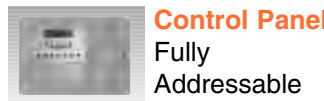

Control Panel
Fully Addressable



DD Series
Duct Damper



EF Series
Easifit Damper



FD Series
Fire Damper



FSD Series
Fire/Smoke Damper



HD Series
Heavy Duty Control Damper



IF Series
Intumescent Fire Damper



SB Series
Single Blade Regulating Damper



SC Series
Smoke Control Damper



SF Series
Slimfit Regulating Damper